

IMPACT OF ADAPTIVE VIRTUAL IMPEDANCE CONTROL OF DERS USED FOR POWER SHARING ON THE PROTECTIVE SCHEMES OF AN ISLANDED MICROGRID

Mojtaba KHEDERZADEH
Shahid Beheshti University, A.C. – IRAN.

ABSTRACT

One of the salient features of the microgrids is operation in an autonomous (islanded) mode. This feature is more pronounced in industrial power plants with heavy duty such as mining, metal, and oil industries; as cyclic and fluctuating loads are the dominant ones in these applications. Distributed Energy Resources (DERs) with small to medium size are predominant in microgrids. Hence, a sophisticated framework is required to supply variable loads by DERs with much smaller ratings. Leading and drafting DERs in a specified sequence is a prescribed solution in this regard, which could be achieved by using virtual inertia and/or virtual reactance. However, the required changes in the existing inertia/reactance have a major impact on the protection schemes applied for DERs and also the distribution network. Nuisance tripping and fail to trip are the consequences of such countermeasures to alleviate the premature fatigue of some of the DERs and related storage systems that are electrically nearer the load than the others. The proposed relaying concept is a communication-assisted scheme that prepares a permissive signal for conventional instantaneous/time-delayed overcurrent relays to inhibit the nuisance tripping in transient conditions; and assure correct tripping in fault cases dealing with the blindness of the relays upon insertion of extra reactance in the fault path.

INTRODUCTION

Heavy industries like metal, mining, excavation for oil, etc., use large and fluctuating loads. Some instances could be crushers, excavators, conveyors. These kind of industries are diverting toward environmental friendly plans. Microgrids exploiting renewables are suitable candidates in this regard. Generally, microgrids are composed of a cluster of Distributed Energy Resources (DERs) such as Fuel Cells, CHPs, PV arrays, Microturbines, Wind Turbines and so on with the capability of operating connected to the grid or autonomously. It is worth noting that the rated capacity of these DERs are much smaller than the conventional power plants, meanwhile, the load ratings of the industrial plants are much higher than any individual DER available in the microgrid. Therefore, there is a tendency toward integrating small DERs in order to supply fluctuating and cycling loads common in industrial plants in a reliable and stable manner in both utility-grid connected mode and autonomous (islanded

mode) [1]-[2].

For operating a power system in most economical method, the power generating units are optimally dispatched to meet the consumption. However, DERs are mainly considered as non-dispatchable units as their generation depends on the weather condition, moreover, the rate of rise of the generation of DERs are slow in comparison to conventional thermal power plants. So, for dealing with this phenomenon, energy storage devices in a microgrid are required. Illindala [1]-[2] proposed a new framework called *Flexible Distribution of Energy and Storage resources* (FDERS) to aggregate DERs in order to be able to supply industrial loads in a microgrid, especially in island mode. It is assumed in [1]-[2] that each DER such as microturbine or fuel cell are complemented by a storage device such as battery to cope with the fluctuations of the load.

The main concern in [1]-[2] is the expiring of the useful life of the batteries in a heterogeneous way, i.e., the batteries with shorter electrical length to the load participate more frequently in charge/discharge duty in responding to fluctuating loads. As the DERs are not fast enough to meet the load requirements in the transient period, so the batteries intervene and provide the required energy to the load, after the proportional increase of the DER output, the battery is charged and ready to perform this task at the next step. Meanwhile, the batteries associated with further DERs do not discharge the same as the nearest one, hence it could have a longer lifetime regarding a constant charge/discharge cycles. The authors have simulated this phenomenon by the V-shape formation of flocks of birds [3] and the peloton/echelon formation of cycling racing teams [4]. The main idea is the leading entity (bird or cyclist) spends the most effort, while the others drafting in the rear use the slipstream that has been created by the leader; therefore spend less effort. If this condition exists, the result is the early exhausting of the leader, while the drafting ones still have enough strength to continue the job. Hence, a pecking order is planned to best exploiting their relative strength. In other words, reinvigoration of all the available participants is performed by periodic rotation [3]-[4].

The problem of leading/drafting of the DERs in a microgrid could be interpreted as the power sharing among the generating units and storage devices. This is performed by virtual reactance, virtual inertia and adaptive control systems [5]. Virtual reactance and virtual inertia insertion into the control system of DERs make them adaptive to the pecking order plan. However, step changes in the actual reactance creates overshoots in

the output current of the DERs and make them susceptible to false tripping. Some modifications are proposed in [1] to the existing microgrid relaying schemes. The main concern is related to the erroneous fault detection during the step changes in synthesized reactance or virtual inertia. The remedial action is based on a high impedance differential protection to alleviate the nuisance tripping of the overcurrent relays. The proposed high impedance differential relay uses the output currents of all the available DERs and also the input current of the load.

The main issue in this regard is the assumption that all the DERs are in the vicinity of each other, so it is possible to collect the currents of the current transformers by cable. This is not the case for scattered DERs in a wide area. Whenever the DERs are far from each other, it is not possible to collect the outputs of the CTs by cable, as it is usual in a busbar protection scheme within a substation. Therefore, a new protective scheme based on a multi-agent system is proposed. The communication-assisted fault detection scheme comprises of distributed agents, located in the outputs of the concerned DERs and the load. The proposed scheme is promising for a dependable and secure microgrid system. Phasor measurement units (PMUs) are used to measure the currents of each DER and also the industrial load, thereafter the phasors are communicated to the differential protection scheme that is located in the microgrid control center (MCC). Then, the phase angle differences of each phase of the DERs and the load are calculated and the result of fault/no fault is transmitted to the overcurrent relay of each DER. The trip command is issued if the associated overcurrent relay AND the received signal from the differential protection scheme verify the existence of a fault. In this way, the transient currents caused by the step changes of synthesized reactance and virtual inertia used for changing the pecking order of the DERs would not be mistakenly recognized as a fault.

In this paper, the impact of synthesized reactance and virtual inertia used for line impedance mismatch compensation in an autonomous microgrid is analyzed. Although the active and reactive power sharing accuracy is improved by using virtual reactance/inertia, it could reversely affect the associated protective relaying. Overcurrent protection schemes are studied in particular, and the analysis results demonstrates that these schemes will be affected by virtual inertia of DERs at the transient state. Therefore, an effective protection scheme is proposed to mitigate the maloperation of protection devices. The proposed method is applied through a multiagent (MAS) framework. Each DER is equipped with an agent and the agents interact with each other through a sparse communication network to realize the common control objective [8]-[12].

POWER SHARING AMONG DERS

Active power sharing between DERs in a microgrid

could be performed by conventional droop control more or less the same as power sharing between large synchronous generators in an interconnected power system. However, the reactance of the transmission lines are dominant with respect to medium or low-voltage lines in a microgrid, with higher resistance. So, the coupling between active and reactive power may degrade the conventional droop control performance in transient response and power sharing accuracy. Therefore, introduction of virtual inductive impedance to the primary control loop would help to decouple the active and reactive power flow. Droop characteristics of the interconnected DERs are designed in such a way as to share the total demand in proportion to their nominal ratings. This attention would lead to a steady state power sharing which is independent from their locational placement within the microgrid. In contrast, the dynamic behavior of each DER is dependent to much extent on its electrical locational placement within the microgrid as well as its controller design [2], [5]. Therefore, it is required to change periodically the electrical locational placement of different DERs (virtually not physically) by applying synthesized reactance and virtual inertia. This could be achieved by adding a virtual reactance to produce an inner loop voltage controller reference for each DER. Figure 1 shows the concept of virtual reactance. As can be deduced from this figure, the insertion of X_{add-i} could affect the electrical locational placement of each DER. The time constant in the DER outer loop power controller block diagram could be used to change the virtual inertia of each DER.

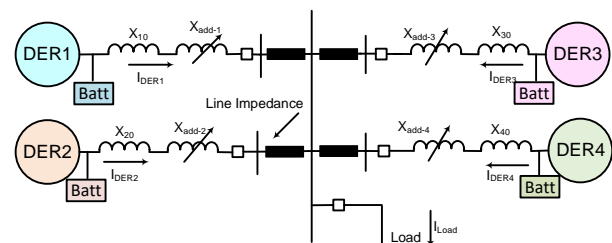

Figure 1: The schematic diagram of the proposed method in normal operation.

LEADING/DRAFTING SIMULATION

In order to illustrate the leading/drafting concept and their interchange, a simple hybridization of a supercapacitor with a battery is used. The supercapacitor is connected to a Buck/Boost converter and the battery is connected to a Boost converter. Power of the battery is limited by a rate limiter block, therefore the transient power is supplied to the DC bus by the supercapacitor. This simple example is simulated in the MATLAB/Simulink environment [6]-[7]. Figure 2 (up) shows the supplied power by the combination of the supercapacitor and the battery, and the lower figure shows the required power. The required power pattern is: [2000 1500 1250 1000 1000 1000 500 0 0 0] W at 1s intervals. At $t=0$, the required power is 2000 W, then

decreases to 1500 W at $t=1s$ and so on. The pattern is repeated from 10 to 20s.

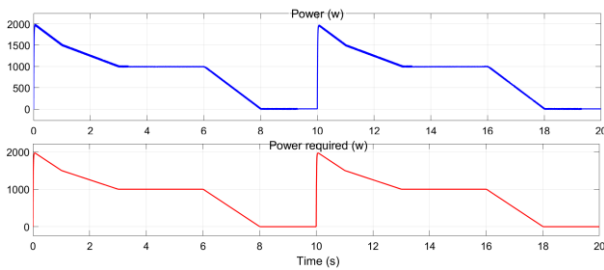

Figure 2: Power output of the combination of supercapacitor and battery versus the required power.

Figure 3 shows the output powers of the supercapacitor and the battery. As can be deduced, at $t=0$, the required power is supplied by the supercapacitor, then gradually the supercapacitor is discharged and the output power of the supercapacitor is decreased until $t=3s$, at which the output power of the supercapacitor is reached to zero and the battery output to 1000 W as required. In this scenario, the leading source is supercapacitor and the drafting one is the battery.

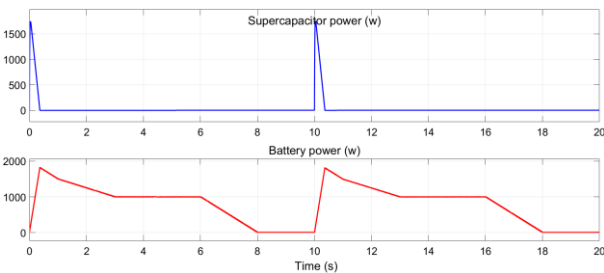

Figure 3: Output powers of supercapacitor (up) and battery power (down). Leading source is the supercapacitor and the drafting one is the battery.

In another scenario, the leading source is the battery and the drafting one is the supercapacitor. This is illustrated in Figure 4. As can be seen, the main power supply is the battery and the supercapacitor role is minor.

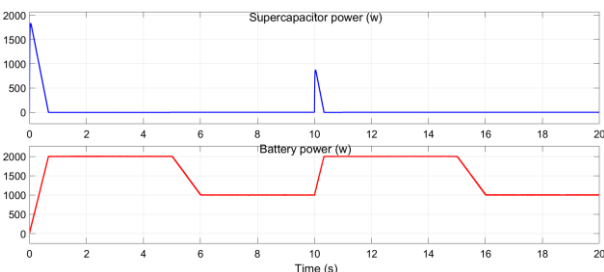

Figure 4: Supercapacitor (up) and battery (down) powers. Leading source is the battery and the drafting one is the supercapacitor.

Figure 5 shows the current, voltage and SOC of the supercapacitor when the supercapacitor is leading. As can be seen, the current has an overshoot, so the overcurrent relays are vulnerable to false operation due to the transient of the current.

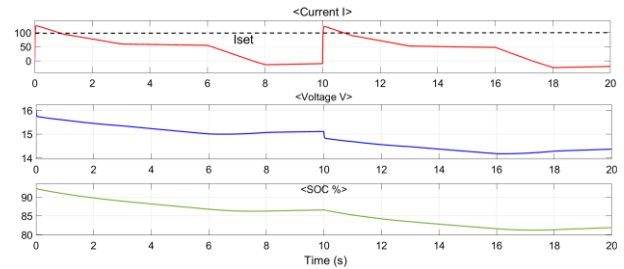

Figure 5: Current, voltage and SOC of the supercapacitor when the supercapacitor is leading. Overcurrent relays are vulnerable to false operation due to the transient of the current.

PROPOSED METHOD

Figure 6 shows the proposed method schematic diagram showing the interaction between the overcurrent relays and the overall differential protection. As can be seen from this figure, each DER is equipped with an instantaneous/time-delayed overcurrent relay combined with the signal received from the differential protection scheme [8]-[12]. During normal operation, a step change in the DER impedance by inserting a virtual reactance would cause transient currents more than the relays' settings initiating them to operate, but the signal from the differential protection scheme is zero, so inhibits the initiation of a trip signal.

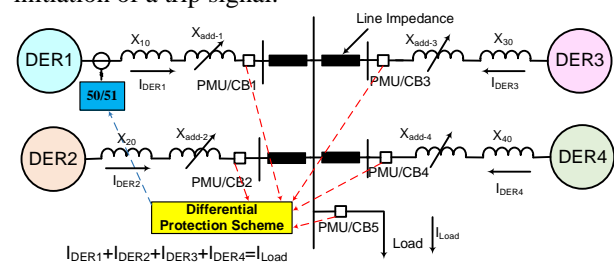

Figure 6: The schematic diagram of the proposed method in normal operation.

Figure 7 shows the same network with a fault on DER1. In this case, the conditions for initiation of the trip signal is fulfilled. Differential protection scheme operates the same as conventional busbar protection. It is based on the KCL principle. When there is a fault, some currents are reversed with respect to their previous direction; the PMUs at DERs and the load measure the current phasors and transmit them for the differential protection scheme [13].

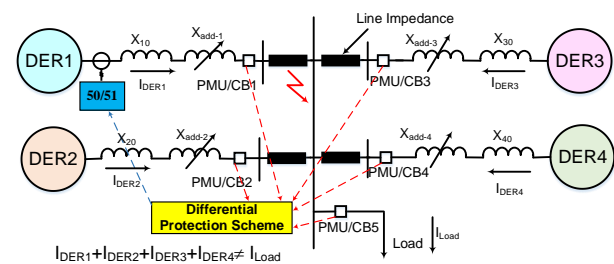

Figure 7: The schematic diagram of the proposed method in fault condition.

As the overall sum of the currents' phasors is not zero, so a transfer trip signal is sent to the overcurrent relays. The picked-up relays would send the trip signal to the associated CBs.

Figure 8 shows the trip logic available at each DER. As can be deduced from this figure, the trip signal for each phase is issued whenever a permissive signal is received from the differential protection scheme.

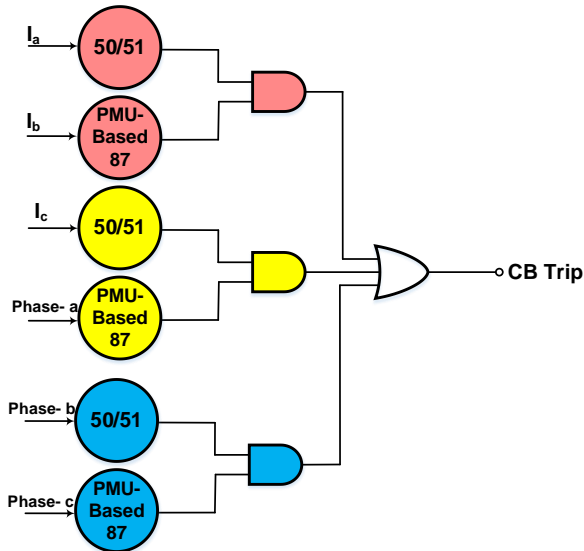

Figure 8: Protection logic of each DER.

CONCLUSIONS

In this paper, the protection of microgrids comprising of small-sized DERs supplying large fluctuating industrial loads is investigated. It is shown that conventional droop control is problematic in microgrids with small DERs because there is a remarkable coupling between active and reactive power flows due to the higher resistance of the line impedances. Even if power sharing could be correctly performed in steady-state, it is undesirable in transient conditions. This could result accelerated aging for the leading DERs, unless the leading and drafting units are periodically exchanged. Virtual reactance and virtual inertia are solutions to change the electrical location of the DERs in order to equally use the potential of each DER. Although insertion of synthesized reactance or virtual inertia are good remedies to insert in the DER's control system, the step change applied has undesired impact on the conventional overcurrent protection used for DERs. A new protection scheme is proposed to alleviate the nuisance tripping of overcurrent protection devices. The proposed scheme is applicable through a multiagent (MAS) framework. Each DER is equipped with an agent (PMU) to measure the current phasor. The agents interact with each other through a sparse communication network to realize the differential protection scheme. In contrast to the local methods, there is no necessity for the units to be geographically near each other. They could be scattered within the microgrid.

REFERENCES

- [1] M.A. Haj-ahmed, and M.S. Illindala, 2015, "Investigation of protection schemes for flexible distribution of energy and storage resources in an industrial microgrid", *IEEE Trans. on industry applications*, vol. 51, no. 3, 2071-2080.
- [2] M.S. Illindala, H.J. Khasawneh, and A.A. Renjit, 2015, "Flexible distribution of energy and storage resources", *IEEE industry applications mag.*, vol. 21, no.5, 32-42.
- [3] P. B. S. Lissaman and C. A. Schollenberger, 1970, "Formation flight of birds," *Science*, vol. 168, no. 3934, 1003-1005.
- [4] A. G. Edwards and W. C. Byrnes, 2007, "Aerodynamic characteristics as determinants of the drafting effect in cycling," *J. Med. Sci. Sports Exercise*, vol. 39, no. 1, 170-176.
- [5] Y. Han, H. Li, P. Shen, E.A.A. Coelho and J.M. Guerrero, 2017, "Review of active and reactive power sharing strategies in hierarchical controlled microgrids," *IEEE Trans. On Power Elec.*, vol. 32, no. 3, 2427 - 2451.
- [6] MATLAB/Simulink, Simscape Power Systems Toolbox, ver. 6.6, R2016b.
- [7] H.J. Khasawneh, and M.S. Illindala, 2014, "Supercapacitor cycle life equalization in a microgrid through flexible distribution of energy and storage resources", *IEEE Trans. on industry applications*, vol. 51, no. 3, 1962-1969.
- [8] H.F. Habib, T. Youssef, M.H. Cintuglu, and O.A. Mohammed, 2017, "Multi-Agent-Based Technique for Fault Location, Isolation, and Service Restoration", *IEEE Trans. on industry applications*, vol. 53, no. 3, 1841-1851.
- [9] M.H. Cintuglu, T. Ma, and O.A. Mohammed, 2017, "Protection of autonomous microgrids using agent-based distributed communication", *IEEE Trans. on power delivery*, vol. 32, no. 1, 351-360.
- [10] H. Wan, K.K. Li, and K.P. Wong, 2010, "An adaptive multiagent approach to protection relay coordination with distributed generators in industrial power distribution system," *IEEE Trans. Ind. Appl.*, vol. 46, no. 5, 2118-2124.
- [11] H. Hyun, and S.H. Kang, 2004, "Adaptive optimal protection of a distribution system using a multiagent system," in *Proc. 8th IEE Int. Conf. Develop. Power Syst. Protection*, 611-614.
- [12] L.C. Zhou, B.H. Zhang, L.Y. Cheng, C.G. Wang, A. Klimek, and Z.Q. Bo, "Centralized substation backup protection with high reliability," in *Proc. 10th IET Int. Conf. Develop. Power Syst. Protection*, 2010, pp. 1-6.
- [13] X.R. Wang, K.M. Hopkinson, J.S. Thorp, R. Giovanini, and K. Birman, 2002, "Developing an agent-based backup protection system for transmission networks," in *Proc. Power Syst. Commun. Infrastruct. Future*, Beijing, China, Sep. 2002.