

PROTECTION SYSTEMS FOR MICROGRIDS WITH HIGH RATE OF INVERTER-BASED-GENERATORS

Philippe ALIBERT
Schneider Electric – France

Jean WILD
Schneider Electric – France

ABSTRACT

Future microgrids will be characterized by a higher penetration rate of inverter-based-generators, up to 100% thanks to “grid forming” inverters. In such configuration, protection systems based on conventional overcurrent protections and time discrimination will be no longer well adapted.

A new protection function is proposed to ensure fault discrimination in all microgrid operating modes, in particular with the lowest short-circuit currents. This new protection function is based on local current and voltage measurements, without real time communication between protection devices. This new function could be already performed in some modern multifunctional protection relays with a customized logic between conventional functions. But in the future, this function could become a “ready to use” function, as the other conventional functions (overcurrent, directional ...).

INTRODUCTION

Existing microgrids are generally supplied with conventional synchronous generators driven by diesel engines or gas turbines. The associated protection systems are based on conventional protection functions, most of the time using basic overcurrent relays with time discrimination to ensure the selectivity. Distributed generators (DGs) based on renewable energy (PV, Wind, Storage systems) can be present, but with a penetration rate below 30% of the total generation power, to meet power system stability requirements.

With the new generation of “grid forming” inverter-based-generators, this penetration rate will increase and future microgrids could be operated with 100% of inverter-based-generators. Such evolution will have strong impacts on protection systems. Conventional phase overcurrent functions (ANSI Code 51) will be no longer convenient to these new requirements.

The following clauses explain these additional requirements on protection systems and a solution is proposed, based on a new protection function called “*Directional Voltage Controlled Overcurrent*” (DVCO). This solution does not require real time communication between protection devices and this protection principle is applicable both to MV or LV microgrids.

NEW REQUIREMENTS ON PROTECTION SYSTEMS IN FUTURE MICROGRIDS

General requirements

Protection systems for microgrids with high penetration

rate of inverter-based-generators have to face several challenges:

- Microgrids could be based on various and complex electrical architectures, in particular in the case of brown fields installations. The generators could be distributed at different locations inside the grid according to installation constraints. Of course, microgrid architecture based on generators concentrated on the same switchboard will simplify the protection system, but such architecture is not always possible.
- Microgrids can be operated with many operating modes, with all possible combination of DGs in operation. To meet the safety requirements, the protection must be ensured in all possible operating modes. To ensure a minimum level of availability, the protection coordination must be ensured in most common operating modes, in particular to facilitate the fault location and reduce the repairing time.

Requirements on “phase” fault detection

In addition to the general requirements listed above, there are two main additional requirements on protection relays to detect “phase” fault. Phase fault means three-phase fault (LLL), or phase-to-phase fault (LL), or phase-to-neutral fault (LN) for 4 wires network (e.g. LV with distributed neutral conductor).

- Short-circuit currents will have low magnitudes. The inverter-based-generators are producing short-circuit currents between one to twice the rated current, according to the withstand of power electronic components inside inverters. According to the operating mode, minimum short-circuit currents in some feeders could be close to the maximum load/rated currents. This issue is not applicable to feeders which feed terminal loads, but it must be solved for the main feeders between switchboards, where the DGs are connected.
- The short-circuit currents will have bi-directional flows inside main feeders, due to DGs.

The two last points are illustrated in Figure 1, with a simplified scheme, where two inverter-based-generators are connected on the same bus.

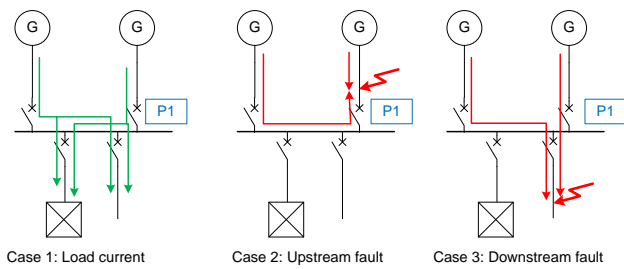

Figure 1: Example of bi-directional short-circuit current

In the example of Figure 1, considering that the two generators in parallel have the same rated power (so same rated current “ I_r ”), the current seen by the protection P1 can be equal to:

- Case 1: “ $\approx I_r$ ” in the downstream direction if the generator is loaded at its rated value
- Case 2: “ $\approx I_r$ ” in the upstream direction (short-circuit current between 1 to 2 times I_r)
- Case 3: “ $\approx I_r$ ” in the downstream direction (nearly the same as case 1)

Of course, the ratio between the total power of DGs which supply the short circuit and the maximum load current in the faulty feeder must be considered. With “terminal” feeders, close to the loads, this ratio can be high enough to ensure fault detection with a conventional overcurrent function. However, this ratio may be not sufficient for feeders which connect different buses where DGs are connected.

In case of insulation failure, even if the short-circuit current is close to or just above a “rated” value, non-operation or long clearing time is not acceptable. This long clearing time could be managed by a thermal overload protection (ANSI 49) or a long-time delay curve of LV trip unit. Such behavior is not acceptable for the two following reasons:

- A “phase” fault (LLL, LL, LN) is generally linked to an insulation issue inside cables, loads, etc. At the insulation failure location, the short-circuit current (even if its magnitude is limited) generates an electrical arc, so a hot spot with a temperature able to generate a risk of fire. To avoid this risk, the fault must be cleared within few seconds (typically below 2s).
- During the “phase” fault, according to the fault impedance, phase-to-phase or phase-to-neutral voltage are close to zero (between 0% to 50% or the rated value). As the short-circuit current is low, the voltage sag due to the fault is nearly the same for all microgrid buses. Such voltage sag cannot be supported by some loads during a long time and must be cleared as soon as possible.

In conclusion, additional features are required to manage phase fault with these low magnitude short-circuit currents, to ensure discriminate fault clearing.

Requirements on “earth” fault detection

As explained in previous sub-clauses, if bi-directional and low magnitude short-circuit currents in case of “phase” short-circuit is an issue for conventional phase overcurrent protection (ANSI code 51), phase-to-earth (or phase-to-ground) short-circuit detection could remain simpler. Generally, in LV or MV microgrids, the earthing system is based on a single location of neutral-to-earth/ground connection. In that case, the **residual** short-circuit current is unidirectional, always from the earthing connection to the earth fault (there is only one short-circuit generator regarding the residual current). The presence of capacitive currents in healthy feeders are not considered at this level.

Thanks to this single earthing connection, the protection system to detect earth faults can be based on conventional residual overcurrent (ANSI Code 51N/51G) associated with usual time discrimination. The timer delays will be set as it is done today in usual MV or LV protection systems: from lower values for terminal feeders, and additional time step for upstream protection stages, up to the earthing connection.

If the earth fault magnitude is also limited by the DG characteristics, sensitive residual overcurrent (ANSI Code 51N/51G) can be used, connected to core balance CTs or based on RCD (Residual Current Devices) or GF (Ground Fault) devices inside LV grids.

NEW PROTECTION FUNCTION: PHASE DIRECTIONAL VOLTAGE CONTROLLED OVERCURRENT (DVCO)

As explained in the previous clause, if the detection of “Earth” faults can be solved with convention residual overcurrent (ANSI 51N/51G), phase overcurrent (ANSI 51) could be not sufficient to detect “phase” fault, due to bi-directional and low magnitude short-circuit.

This detection can be ensured based on a logic combination of two specific functions:

- Voltage Controlled Overcurrent (VCO, or ANSI Code 51V, or LN PVOC)
- Phase directional element (ANSI Code 67, or LN RDIR)

These two functions must be performed with specific features. The operation is built with an “AND” logic gate between both operate outputs. These two functions are explained in the two following sub-clauses and the setting rules are developed in the next chapter to ensure the right protection coordination.

Voltage Controlled Overcurrent (VCO or ANSI Code 51V)

Inside microgrids with high rate of inverter-based generators, the short-circuit currents can be close or just above “rated” currents. The great difference between normal load conditions and short-circuit conditions remains in phase voltage levels. In case of short-circuit,

one or several phase-to-phase or phase-to-neutral voltages of microgrid busbars are very low (between 0% to 50% of rated values).

To ensure the right detection of short-circuit currents, protection based on voltage controlled overcurrent (VCO) can be used on specific feeders. This function is based on the principle described in Figure 2.

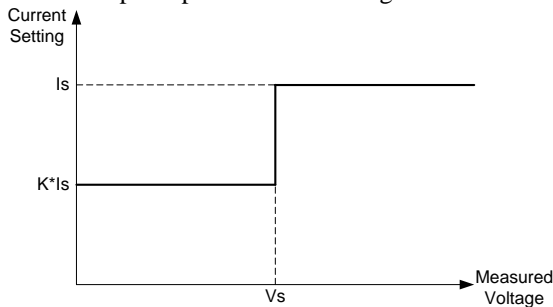

Figure 2: Voltage Controlled Overcurrent characteristic

The voltage controlled causes the overcurrent setting to change from I_s to $K \times I_s$ in a stepwise manner when the input voltage falls below the voltage threshold V_s . K is a multiplier set by the user.

The relationship between current threshold I_s and measured voltage V is as follows:

- $V > V_s \Rightarrow$ Current setting = I_s
- $V \leq V_s \Rightarrow$ Current setting = $K \times I_s$

The threshold V_s is compared to the **minimum value between the 3 phase-to-phase voltages and the 3 phase-to-neutral voltages**, to ensure right detection of all phase fault types (LLL, LL, LN), with 3 wires system (HV or MV grids) of 4 wires system (LV grids with distributed neutral conductor)

Phase directional element (ANSI Code 67)

With distributed generators inside the microgrids, the short-circuit currents seen by feeder protections could be in both directions. To ensure right fault discrimination, the VCO explained above must be associated to a phase directional element, to manage two different time delays, one for the downstream direction and one for the upstream direction.

The directional element can be based on the same principle than phase directional functions used in MV or HV protection relays. For example, the directional element can be polarized by phase-to-phase voltage in “quadrature” regarding phase currents, as shown in Table 1 and Figure 3.

Phase of Protection	Operating Current	Polarizing Voltage
A	I_A	$U_{BC} = V_B - V_C$
B	I_B	$U_{CA} = V_C - V_A$
C	I_C	$U_{AB} = V_A - V_B$

Table 1: Example of directional polarizing method

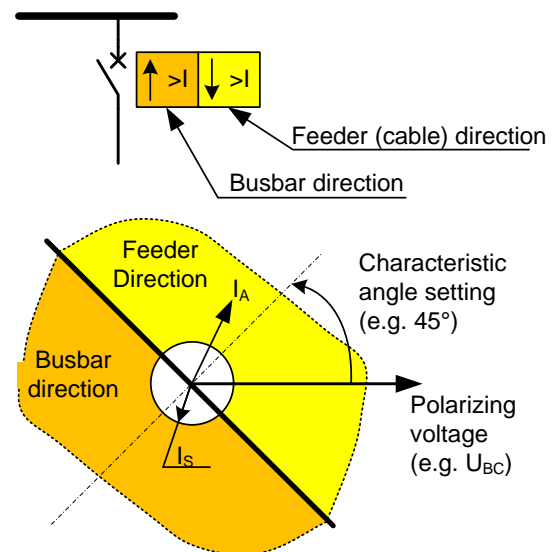

Figure 3: Direction element principle

The directional element shall be equipped with a voltage memory to manage a “bolted” three phase fault close to the directional protection. In that case the three phase-to-phase polarizing voltages are close to zero and the directional element is based on phase voltages memorized just before the fault.

Two separate VCO (or 51V) elements are used and each of them is associated with a directional element (set in Feeder or Busbar direction) with an AND logic gate between the two criteria. With such combination, the two 51V elements can be set with two different time delays (T_1 & T_2), applicable for each direction (i.e. feeder side and busbar side), as illustrated in Figure 4. The timer setting rule is developed in the following chapter.

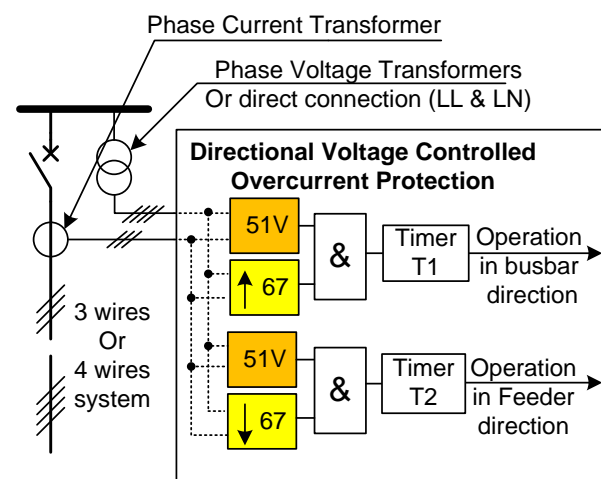

Figure 4: Directional voltage controlled overcurrent (DVCO) protection principle

“DVCO” APPLICATION & SETTING RULES

Conditions to use DVCO at the place of conventional overcurrent function

The DVCO must be used when the minimum short-

circuit current for phase fault (LLL, LL or LN faults), computed in all possible (or authorized) operating modes, is below or close to maximum load currents. Generally, this condition is fulfilling for high rated current feeders, on main buses or main feeders which ensure the link between buses where distributed generators are connected.

DVCO recommended settings

- Is threshold is defined as usual to be above the maximum load current, in both directions, and below the minimum short-circuit in on-grid mode (if existing, so with highest short-circuit currents). The maximum load current value can be based on loads or generators located upstream or downstream the corresponding circuit breaker. This current can also consider some transient currents due to nonlinear loads (motor starting current, transformer inrush currents ...). This threshold will operate in the on-grid mode without any voltage conditions, as it is done in usual protection systems based on overcurrent functions.
- K ratio (or $K \times I_s$ current value) is defined to get a threshold under the minimum short-circuit current computed in all possible operating off-grid modes and for all fault types (LLL, LL, LN). It's recommended to set this value above normal load current but the setting can be under the maximum load current, because this "sensitive" overcurrent is enable only during strong voltage sag (due to short-circuit conditions). In some specific off-grid operating modes, the minimum short-circuit could be below the maximum load current.
- Vs voltage threshold is set to 0.7 times the rated voltage. Normal operating voltages are generally between $\pm 10\%$ around the rated value. With some transient events (motor start, inrush current after voltage dip, ...), the voltage drop could be up to 20%. LV installation guides are based on maximum voltage drop up to 8%, with transient voltage drop up to 15%. The setting value must be also set in accordance with FRT requirements (Fault Ride Through) defined in local grid codes, and applicable in on-grid mode.
- Two different time delays are defined for the two directions. For each direction, the time delay is defined with a time discrimination between protection stages in one specific direction.
 - The directional element based on "downstream" direction (e.g. feeder) must be time coordinated with downstream protection stages only
 - The directional element based on "upstream" direction (e.g. busbar) must be time coordinated with upstream protection stages.
 Usual time discrimination step is used between the protection stages. The time delay must be defined according to the maximum time delay of the

downstream protection stages plus the required time step (e.g. 0.1s in LV, 0.2 in MV or more).

A simple use case where generators are distributed on two different busbars is illustrated in Figure 5. The timer settings of DVCO elements are defined with a time step of 0.2s. The same approach can be performed with multiple locations of distributed generators.

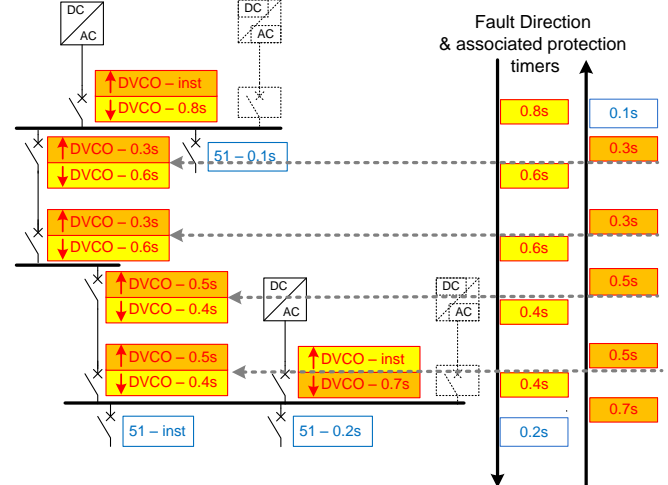

Figure 5: time discrimination with DVCO functions

CONCLUSIONS

With the DVCO (Directional Voltage Controlled Overcurrent) and conventional residual overcurrent, a protection system with right discrimination can be performed for microgrids with high penetration rate of inverter-based-generators. The proposed protection system does not require real time communication infrastructure.

The proposed DVCO function can be already performed with modern multifunctional relays, based on customized logic and conventional protection functions: undervoltage element (ANSI 27), phase directional element (ANSI 67) and phase overcurrent (ANSI 51). But in future protection relays or LV trip units, the DVCO could become a "ready to use" function, well adapted to specific requirements of future microgrids.

REFERENCES

- [1] Xiaoyang Peng (ENGIE), Jean Wild (Schneider Electric), 2017, "Innovative Microgrid Solution for Renewable Energy Integration within the REIDS Initiative", *Applied Energy Symposium & Forum: Low Carbon Cities & Urban Energy Joint Conference, WES-CUE 2017, 19–21 July 2017, Singapore*.
- [2] IEC 60255-151 – 2009-08 *International Standard – Measuring relays and protection equipment – Part 151: Functional requirements for under/over current protection*.