

ROBUST HOLISTIC ARCHITECTURE FOR SMART POWER SYSTEMS

Albana ILO
TU Wien – Austria

Christian SCHIRMER
TU Wien - Austria

Daniel-Leon SCHULTIS
TU Wien - Austria

ABSTRACT

This paper describes a new robust architecture, which is based on a holistic approach. It is an architecture of power systems in which all relevant components like electricity producer and storage (both regardless of the technology and size), grid (regardless of voltage level), customer and market, are merged into one single structure. It unifies all interactions within the power system itself and between it and market thus creating the possibility to harmonize them.

INTRODUCTION

The penetration of many decentralized generation (DG) units changes drastically the structure of the electricity supply. Their traditional technical/functional architecture cannot longer fulfil the daily requirements on power supply. Power industry is experiencing serious technical problems in the management and use of the existing transmission and distribution grids. Microgrid concept was introduced many years ago to handle the integration of distributed energy resources. The focus of the Microgrids concept is set on distribution grid; transmission grid is implied in the “host power system”, which in many cases includes also parts of distribution grid. Although the detailed definition of Microgrids is still under discussion in technical forums [1], a Microgrid architecture based on the Matryoshka-doll principle is crystallized [2]. Its realization requires extremely ramified and complex coordination [1, 3]. The size of a Microgrid is still not defined, that makes their practical implementation almost impossible. The interactions between the transmission and distribution grids can hardly be considered. Trying to solve technical problems,

other problems have arisen in the field of data privacy and cyber security [4].

This paper presents a new technical/functional operation architecture. Firstly, the technical and market-related holistic model is introduced. Secondly, the different levels of the holistic architecture including the LINK-Paradigm are described. Finally, conclusions are drawn including a quick comparison of LINK and Microgrids related solutions.

HOLISTIC MODEL

The integration and the effective use of all available resources connected on the grid is possible only under a holistic view of power systems [5]. Figure 1 shows an overview of the holistic power system model. Figure 1a) shows the technical holistic model “Energy Supply Chain Net” [6], which is conceived in two axis:

1. Horizontal

In the horizontal axis are set interconnected High Voltage Grids (HVG), which actually are operated from Transmission System Operators (TSO).

2. Vertical

On the vertical axis are set Medium and Low Voltage Grids (MVG and LVG), which actually are operated from DSO and Customer Plants Grids (CPG) which are under the ownership of the house lord. The supplier –i.e. photovoltaic installed on the roof -, storages i.e. - electrical car battery and cooling- and heating systems – are connected with each other via the house intern grid. To include customer plants in the holistic model, a precise definition of prosumers or consumers was required as follows: **Prosumer** is a natural or legal person being owner of small electricity or/and storage

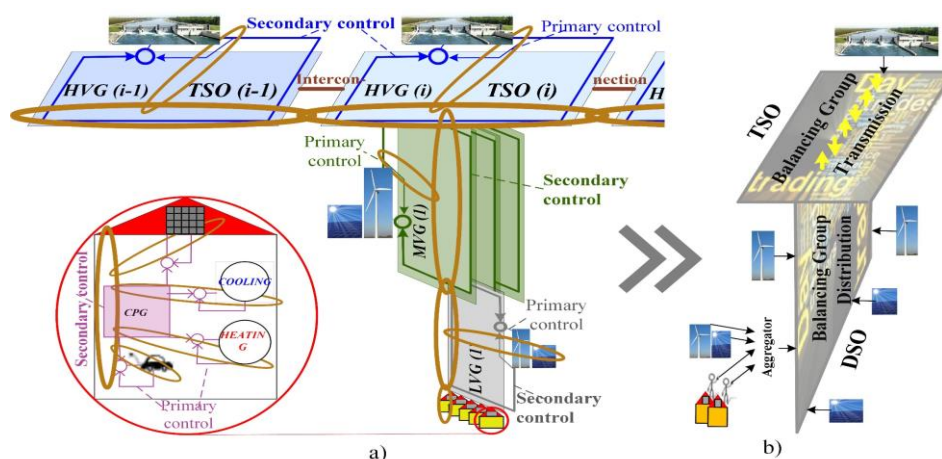

Figure 1 Overview of the holistic model: a) technical; b) market-related

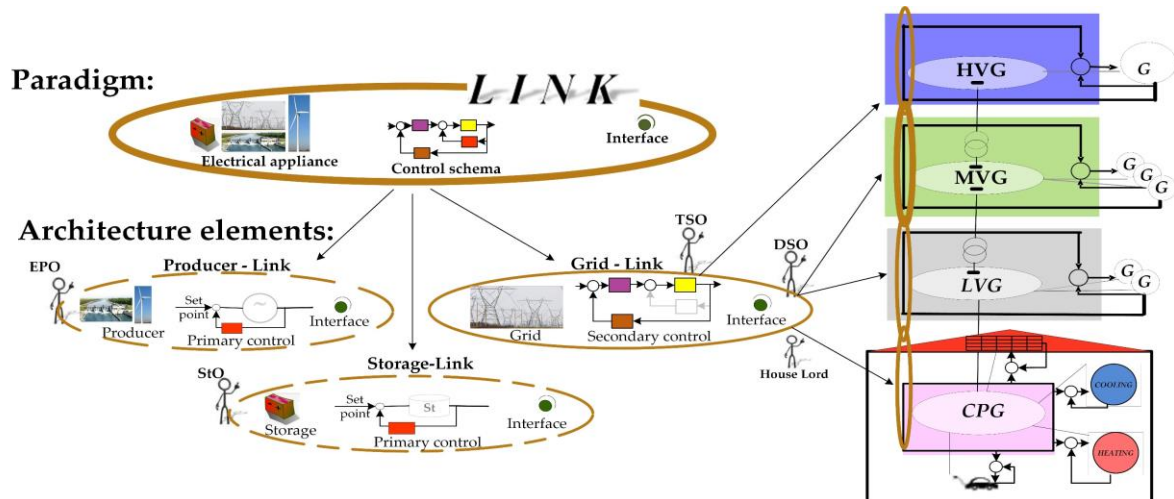

Figure 2 Overview of the *LINK*-paradigm and the deduced architecture elements

facilities which are connected with each other through his own grid. He is connected to the power grid, but the produced electricity is mainly used to supply his own load. He is selling his electric energy surplus, and buying electric energy for its own use.

Therefore, power grid including customer plants are arranged in autonomous parts as links in a chain net as defined in the following.

The “Energy Supply Chain Net” is a set of automated power grids, intended for chain links, abbreviated links, which fit into one another to establish a flexible and reliable electrical connection. Each individual link or a link-bundle operates autonomously and have contractual arrangements with other relevant boundary links or link-bundles.

Figure 1b) shows an overview of the holistic electricity market-related model, which is a mirror of the technical one. Based on this model not only the TSO [7], who operates on the horizontal axis of power systems, but also the DSO, who operates on the vertical axis of power systems, will communicate directly with the market and take over the task of load-power injection balance. The owner of the decentralized appliances may participate directly or via an aggregator in the market.

HOLISTIC ARCHITECTURE

Holistic architecture is an architecture that considers a complex system as a coherent whole that is also part of something greater. To understand and model the highly complex power system operation processes in presence of the DGs and highly volatile nature of the newest renewable energy resources, is established a smart grid paradigm. *LINK*-Paradigm is used as an instrument to design the new technical/functional architecture.

LINK-paradigm

A technical system can be characterized by three major elements: Hardware; Automation and Communication. Breaking down these elements into power systems results that the hardware consists of electrical appliances that

means grid, storage or producer devices, while the automation and communication consist of control schemas and interfaces respectively.

LINK-paradigm is a composition of an electrical appliance (be a grid part, producer or storage), the corresponding controlling schema and the Link interface. Figure 2 shows an overview of the *LINK*-paradigm and the deduced architecture elements.

Architecture elements

There do exist only three independent main power system components –i.e. Producer, Storage and Grid-, which create the base for the definition of architecture elements which are defined as follows:

1. **Producer-Link** is a composition of an electricity production facility be a generator, photovoltaic, etc., its Primary-Control and the Producer_Interface.
2. **Storage-Link** is a composition of a storage facility be the generator of a pump power plant, batteries, etc., its Primary-Control and the Producer_Interface
3. **Grid-Link** is a composition of a grid part, called Link_Grid, with the corresponding Secondary-Control and the Link_Interfaces. The Grid-Link contains secondary control for both major entities of power systems frequency and voltage. The secondary control algorithm should fulfil technical issues and calculate the set points by respecting dynamic constraints which are necessary for a stable and reliable operation. The **Link-Grid size** is variable and is defined from the area, where the Secondary-Control is set up. Thus the Link_Grid may include for e.g. one subsystem (the supplying transformer and the feeders supplied from it) or a part of the sub-transmission network, as long as the secondary control is set up on the respective area. The Link_Grid size is variable and may apply to a customer plant or even to a large high voltage grid area.

Different architectural levels

Figure 3 shows an overview of the different *LINK*-based architecture levels:

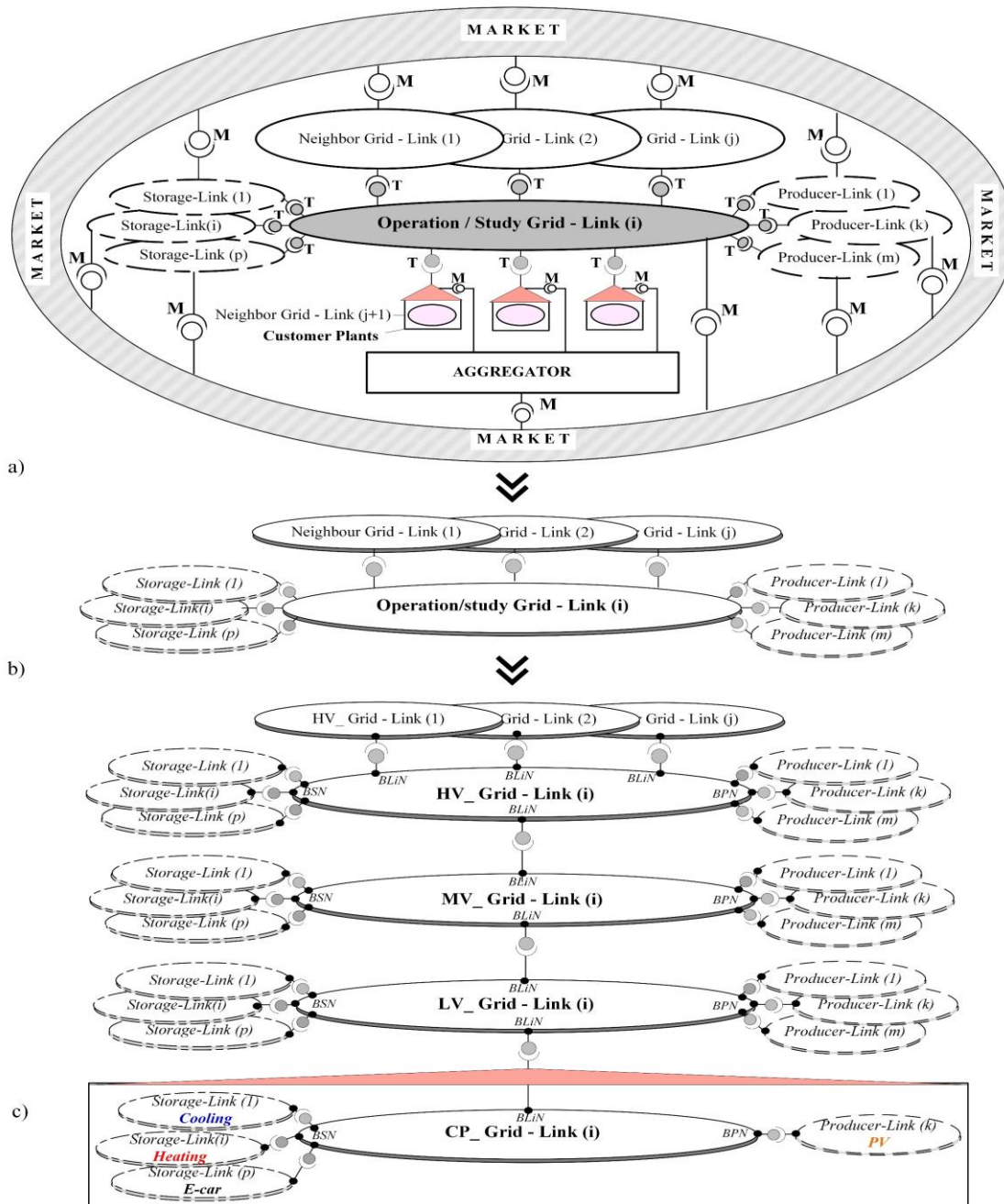

Figure 3 Different *LINK*-based architectural levels: a) unified b) generalized and c) technical/functional

Figure 3a) shows **the unified *LINK*-based architecture** which consists of two parts: technical and market-related. The technical part is located at the center and is surrounded by the market part, which is presented via a loop-band. In center is set the “Operation or study Grid-Link”, which actually presents a generalized composition of both power- and customer plant grids. Figure 3b) shows **the generalized technical architecture**. In Figure 3a) the Grid-Link of customer plants are taken out from the generalized presentation because they are too small to participate directly into the common market. They participate into the common market only through the aggregator. The Grid-Link of the customer plants are presented as neighbor Grid-Links. Data privacy and cyber security are the two biggest challenges today. To

overcome them the distributed *LINK*-based architecture is chosen. Its key principle is to prohibit access to all resources by default, allowing access only through well-defined boundary points, i.e. interfaces. Therefore, the “Operation or study Grid-Link” communicates via well-defined technical interfaces “T” [5] with the other neighbor Grid-Links, Producer- and Storage-Links, which are connected directly to its own grid. The technical Links communicate with the common market via the market interfaces “M” [7]. All technical issues are encapsulated in the generalized technical *LINK*-based architecture, Figure 3b).

Figure 3c) shows **the technical, functional *LINK*-based architecture** of power systems. Per definition the “Grid-Link” can be set-up on any part of the grid.

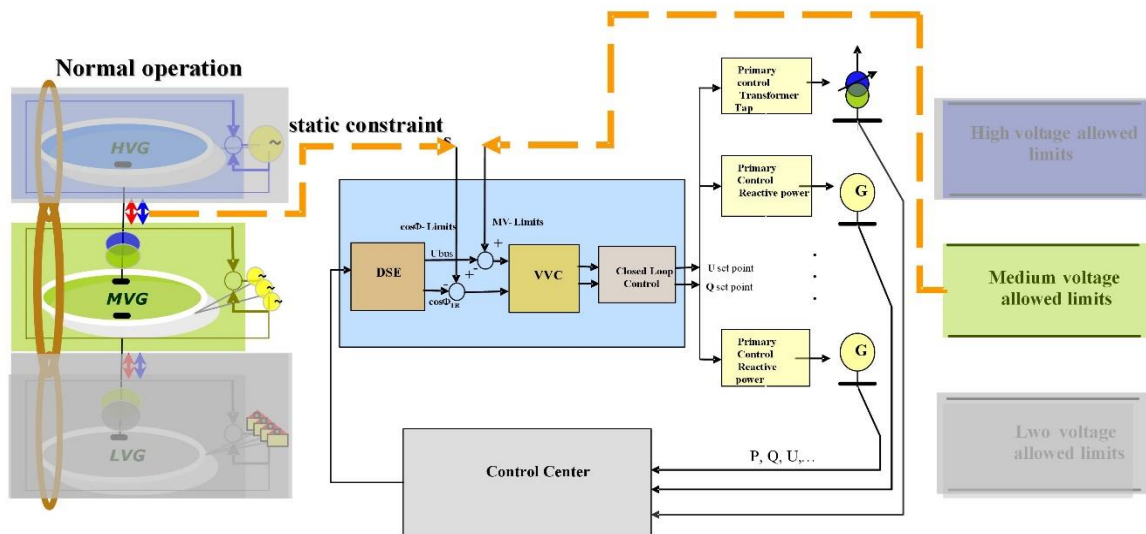

Figure 4 Volt/var control in medium voltage level, realized in the framework of the *LINK*-based architecture

In Figure 3c), the "Grid-Link" presentation is restricted to the three popular voltage level grids. From this architectural level, it is possible to jump to the management system level to see how different applications are integrated into a predefined operational process, which can be described easily [5, 7].

Figure 4 shows the implementation of the Volt/var control process in management system level. It was realized in medium voltage level by means of the secondary control by using the distribution system estimator (DSE) and Volt/var control (VVC) applications. DGs were upgraded with reactive power primary controls [8]. The Link_Secondary-Control was set in closed loop, which means that the voltage was automatically controlled and simultaneously the grid was being dynamically optimized in real-time by respecting the $\cos(\varphi)$ constraint on the HV/MV intersection point.

Operation modes

The new designed architecture facilitates three operating modes: **autonomous** - each individual Link or Link-bundle operates independently by respecting the contractual arrangements with other relevant boundary Links or Link-bundles; **autarkic** - is an optional operating mode, which may be applied in any Link-bundle, which consists of at least one Grid-Link and one Producer-Link or Storage-Link, as long as it is self-sufficient and -sustaining without any dependency on electricity imports; **restoration** - is an option of the autarkic operating mode, which may be applied after a black out, during the restauration process to supply with electricity at least the communication appliances.

CONCLUSIONS

Similar to Microgrids, *LINK* enables parts of grids to operate autonomously. The combination of at least two Links, a Producer-Link and a Customer Plant_Grid-Link, can be operated autarkic. Unlike Microgrids, *LINK* handles the transmission and distribution grid and the

customers all together, thus allowing the consideration of the internal dependencies of the power system. All operation processes of power systems are described easily. From this level of architecture, it is very easy to go to the EMS or DMS level, as well as to the applications.

REFERENCES

- [1] D.E. Olivares et al., 2014, "Trends in Microgrid control" *IEEE Transactions on Smart Grids*, Vol. 5, Iss. 4, pp. 1905-1919.
- [2] M. Soshinskaya, et al., 2014, "Microgrids: experiences, barriers and success factors", *Renewable and Sustainable Energy Reviews - Elsevier*, Vol. 40, pp. 659-672.
- [3] A.L. Dimeas, N.D. Hatziargyriou, 2005, "Operation of a multi agent system for Microgrid control" *IEEE Transaction on Power Systems*, Vol. 20, No. 3, pp. 1447-1455.
- [4] Z. Wang, K. Yang, X. Wang, 2013, "Privacy-preserving energy scheduling in Microgrid systems", *IEEE Trans. Smart Grid*, Vol. 4, No. 4, pp. 1810-1820.
- [5] A. Ilo, 2016, "Link- the Smart Grid Paradigm for a Secure Decentralized Operation Architecture", *Electric Power Systems Research - Journal - Elsevier*, Volume 131, pp. 116-125.
- [6] A. Ilo, 2013, "The Energy Supply Chain Net", *Energy and Power Engineering*, Vol. 5 No. 5, pp. 384-390.
- [7] A. Ilo, 2017, "Demand Response Process in Context of the Unified *LINK*-Based Architecture", in J.L. Bessède (eds), *Eco-design in Electrical Engineering*, vol. 440, pp. 74-83, Springer.
- [8] A. Ilo, W. Schaffer, T. Rieder, I. Dzafic, 2012, "Dynamic Optimization of Distribution Network - Closed loop operation results", *VDE Kongress*, 5-6 November, Stuttgart, Germany, pp. 1-6.