

COORDINATED CONTROL OF MULTIPLE DISTRIBUTED SOURCES IN ISLANDED OPERATION OF MICROGRID

Yu AN,
Dong LIU

Shanghai Jiao Tong University - China

Qiang LIU,
Qing-Sheng LI

Guizhou Power Grid Co. Ltd. - China

Yun-Hui HUANG
Shanghai Jiao Tong University - China

ABSTRACT

The technical, economic and environmental benefits from the integration of renewable energy sources have led to the development of microgrid. The flexible operation of microgrid between grid-connected mode and islanded mode helps to improve overall power quality and reliability. In this paper, some practical problems related to the secure and stable operation of islanded microgrid are introduced, and the relevant solutions are presented. A coordinated control structure composed of primary control and secondary control is proposed to achieve the seamless transition of the microgrid and the power sharing of multiple distributed sources without droop characteristics. The proposed method was verified and applied in a practical microgrid demonstration project in Guiyang, China.

INTRODUCTION

Compared to conventional generators, the development of renewable energy based distributed sources has provided several advantages by reducing environmental pollution and reserving fossil fuel. The concept of microgrid is introduced for the integration of these distributed sources and the flexible operation of power grid [1]. Normally, the microgrid operates in two modes: grid-connected mode and islanded mode [2]. This control flexibility makes the microgrid itself as a single controlled unit that can supply uninterrupted power, improve local reliability and reduce feeder losses.

To achieve stable and secure operation of the microgrid, especially in islanded mode, a number of technical issues require extensive real-time simulations and trials, which has gained wide attention in engineering and research institutes across the globe [3], [4]. A microgrid demonstration project is developed in a practical distribution network in Guiyang, China¹. In Fig. 1, the microgrid is a 10kV feeder which consists of combined cooling and heating power (CCHP) system, battery energy storage system (BESS), photovoltaic (PV) and wind turbine (WT). Among these distributed sources, the CCHP is rotary based and the others are electronically interfaced. When the main grid is failed or overhauled, the microgrid can disconnect from the utility bus by opening the point of common coupling (PCC) circuit

breaker CB, and the local voltage support should be provided by these distributed sources. However, during the implementation of islanded operation in this project, there are two main practical problems to be solved.

The first problem is the seamless transition of the microgrid from grid-connected operation to islanded operation. In Fig. 1, all the distributed sources have no droop characteristics except CCHP's synchronous generation. Thus, the CCHP is regarded as the only V/f source in islanded operation. Generally, the PCC is directly controlled by the V/f source to reduce the control delay as stated in the traditional methods [5], [6]. However, CCHP fails to have access to the PCC according to the requirements of the National Grid Code. Because the PCC circuit breaker is not on the bus of CCHP but in the possession of the power management system (PMS) of the transformer substation. Therefore, the control architecture of the PCC needed to be reconstructed with alternative scheme based on the PMS.

Secondly, the scale of most CCHP based microgrid applications in previous research was relative small without any other distributed sources involved. Although some recent studies [7], [8] utilized the energy storages to optimize the running curve of CCHP, the integration of other renewable energy resources, especially intermittent sources (PV and WT), were seldom discussed. Due to limited capacity of islanded microgrid, the power fluctuations from PV and WT may increase the difficulty in frequency regulation of V/f source. To avoid this problem, intermittent sources are usually stopped during islanded operation. For example, in Fig. 1, an option is to open the sectionalized circuit breaker SCB, but this will lead to the curtailment of Load 3. In this project, it is expected to achieve the islanded operation of the whole feeder, including all the essential load and renewable energy resources. Thus, to improve the performance of CCHP in islanded operation, the power output of these PQ sources (BESS, PV and WT) should be coordinated to minimize the total fluctuations of microgrid.

Faced with these practical problems mentioned above, this paper provides the feasible solutions to succeed in islanded operation of the whole feeder. A coordinated control architecture with two control layers is illustrated. In this control architecture, the primary control of

¹ This paper was supported by the National High-tech R&D Program of China (863 Program): 2014AA051902.

distributed sources is coordinated and optimized through a secondary control. Besides, the seamless transition of microgrid is also accomplished based on the PMS. The proposed method was finally applied in this practical microgrid demonstration. In the field trial test, all the renewable energy sources on a feeder were well coordinated, and the power fluctuations were also reduced during islanded operation.

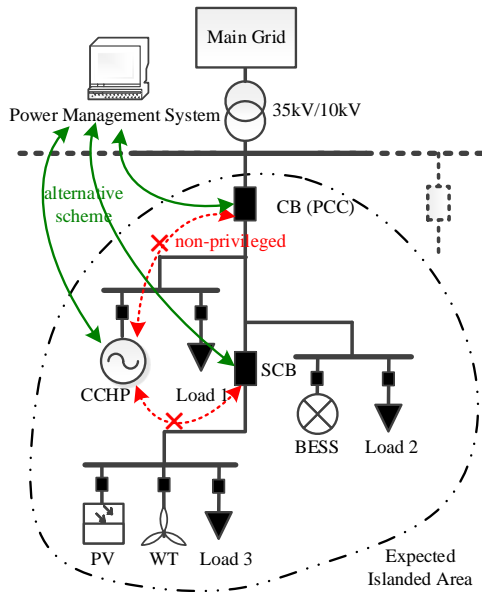

Fig. 1. A practical part of distribution network with multiple distributed sources interconnected.

COORDINATED CONTROL

In this section, as shown in Fig. 2, a coordinated control architecture composed of primary control and secondary control is proposed to achieve the seamless transition and the stable operation of the microgrid.

Seamless transition

With access to all circuit breakers and distributed sources, the PMS is capable of the sequential coordination between PCC and V/f source's mode switching during the disconnection and reconnection of the microgrid. In Fig. 2, before the microgrid disconnects from the main grid, the PMS should firstly identify the feasibility of islanding operation by evaluating the actual load state and power outputs of distributed sources. It can be simply estimated by measuring the exchange power on PCC. Then the PMS adjusts the active power reference of CCHP or BESS to minimize the exchange power. After that, the PMS successively opens CB and transfers the control mode of CCHP from PQ control to V/f control. In the practical field trial, the action time difference between CB and CCHP should be as short as possible, so that the synchronous generator of CCHP has enough inertia to keep the islanded system from collapsing. Finally, the CCHP will work as a slack bus to regulate the voltage of the islanded area by switching its control

mode to V/f control.

Primary control

The primary control of the distributed sources is managed through the local controllers to provide required power output. Before islanding, CCHP and BESS are expected to output constant power under PQ control mode. PV and WT are equipped with maximum power point tracking (MPPT) system to fully utilize the renewable energy resources. After the decoupling of the microgrid, the CCHP changes its control mode from PQ control to V/f control maintaining the specific frequency and voltage of the islanded system, while the other distributed sources are still under the grid-connected operation. The primary control realizes the normal operation of the islanded microgrid based on the V/f control of CCHP. But it fails to coordinate the power support from other distributed sources without droop characteristics. A secondary control must be proposed for the power management of PQ sources during islanded operation.

Secondary control

In the secondary control, the PMS regulates the overall control of islanding operation by providing power dispatch for each PQ source and voltage set points for CCHP. The PMS ensures the safe and stable operation of the microgrid by providing a target P_{Ct} , which is the expected active power output of CCHP in islanded operation. This target value can be determined in the power balance constraint (1), where P_{Df} is the forecast power out of distributed sources (PV and WT), P_{Lf} is the load forecast, P_{Bd}^{max} and P_{Bc}^{max} are the expected maximum discharging and charging power of BESS, respectively. The expected maximum discharging and charging power of BESS are subjected to both rated power and the state of charge (SOC) of BESS in (2)-(3), where E_B is the rated energy capacity of BESS, ΔT is the expected islanded duration, P_{Bd}^{rated} and P_{Bc}^{rated} are the rated discharging and charging power of BESS, $SOC(T)$ is the current SOC of BESS, SOC_{max} and SOC_{min} are the maximum and minimum SOC of BESS, respectively.

$$P_{Ct} + P_{Df} + \frac{1}{2}(P_{Bd}^{max} - P_{Bc}^{max}) = P_{Lf} \quad (1)$$

$$P_{Bd}^{max} = \min \left[P_{Bd}^{rated}, \frac{SOC(T) - SOC_{min}}{\Delta T} \cdot E_B \right] \quad (2)$$

$$P_{Bc}^{max} = \min \left[P_{Bc}^{rated}, \frac{SOC_{max} - SOC(T)}{\Delta T} \cdot E_B \right] \quad (3)$$

The control target P_{Ct} is updated every 15 minutes during islanded operation. In each time interval of this optimization calculation cycle, the power sharing of PQ sources is autonomously managed by the Coordinator, which is a bridge between primary control and secondary control, dynamically adjusting the power references of PQ sources based on the microgrid control error (MCE) control.

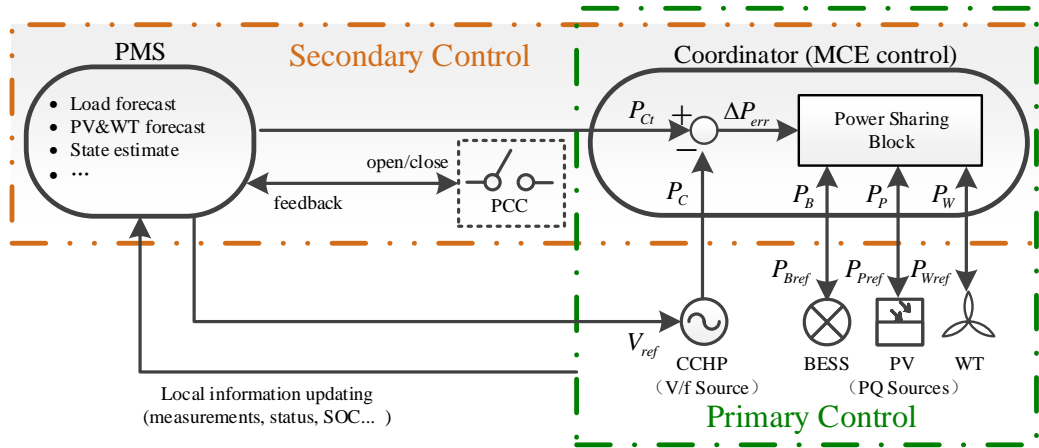

Fig. 2. Coordinated control architecture composed of primary control and secondary control.

MCE control

Technically, during voltage regulation, the output of CCHP P_C is uncontrolled but changes with the power fluctuations of load and other distributed sources. The MCE control is to maintain the total net load of the islanded microgrid, thereby optimize the power output of the V/f source. During MCE control, the power fluctuations is mitigated by power sharing among PQ sources.

The objective function of MCE control is described in (4). When it occurs power fluctuations in islanded microgrid, the MCE control error $P_{MCE} \neq 0$, the new power reference of BESS P_{Bref} should be adjusted according to (5), where P_B is the actual power output of BESS, k_B is the distribution coefficient, which can be calculated in (6) based on the rated power of CCHP P_C^{rated} and rated power of BESS P_B^{rated} .

$$P_{MCE} = P_{Ci} - P_C = 0 \quad (4)$$

$$P_{MCE} + k_B(P_{Bref} - P_B) = 0 \quad (P_{MCE} \neq 0) \quad (5)$$

$$k_B = P_C^{rated} / P_B^{rated} \quad (6)$$

Normally, P_{MCE} can be eliminated with fast discharging or charging response of BESS. However, sometimes in light load situation, the BESS are fully charged, then the Coordinator should lower the power references of PV P_{Pref} and WT P_{Wref} according to (7), where P_P and P_W are the actual power output of PV and WT, respectively.

$$P_{MCE} + P_{Pref} + P_{Wref} = P_P + P_W \quad (SOC = SOC_{max}) \quad (7)$$

On the one hand, by dynamically adjusting the power references of PQ sources, P_C can be maintained in the optimal range for more stable operation. On the other hand, this coordinated control provides a power sharing solution for those distributed sources without droop characteristics.

FIELD TRIAL RESULT

The proposed coordinated control method was evaluated in the field trial test of this practical microgrid

demonstration located in Guiyang, China. As shown in Fig. 1, multiple distributed sources based on renewable energy (including CCHP, BESS, PV and WT) were taken into account in this demonstration application. The range of output power of distributed sources and loads on the tested feeder was presented in Table I.

TABLE I
THE RANGE OF OUTPUT POWER
OF DISTRIBUTED SOURCES AND LOADS

Name	Type	Range
CCHP	Rotary-Based	0~500 kW
BESS	Inverter-Based	-50~50 kW
PV	Inverter-Based	0~90 kW
WT	Inverter-Based	0~50 kW
Load 1	Load	0~150 kW
Load 2	Load	0~150 kW
Load 3	Load	0~100 kW

Firstly, the PMS estimated the feasibility of islanding the whole feeder by observing the exchange power on CB. The PMS would turn down the active power reference of CCHP until the value of this exchange power was lower than the allowed threshold (30 kW), and vice versa. After that, the PMS sent the open command to the feeder terminal unit (FTU) of CB. Then the PMS sent the switching command to the local controller of CCHP to transfer its control mode immediately when the PMS acquired the feedback signal from FTU of CB. The action time difference between CB and CCHP was less than 0.5 second. Finally, the microgrid of the whole feeder switched to islanded operation.

During islanded operation, as the only V/f source, the CCHP automatically changed its power output to meet the demand of total load with power fluctuations. The PMS forecasted the possible load demand and provided a control target (130 kW) for the Coordinator. According to this target power, the power references of PQ sources were coordinated based on the MCE control. The performance of MCE control is illustrated in Fig. 3.

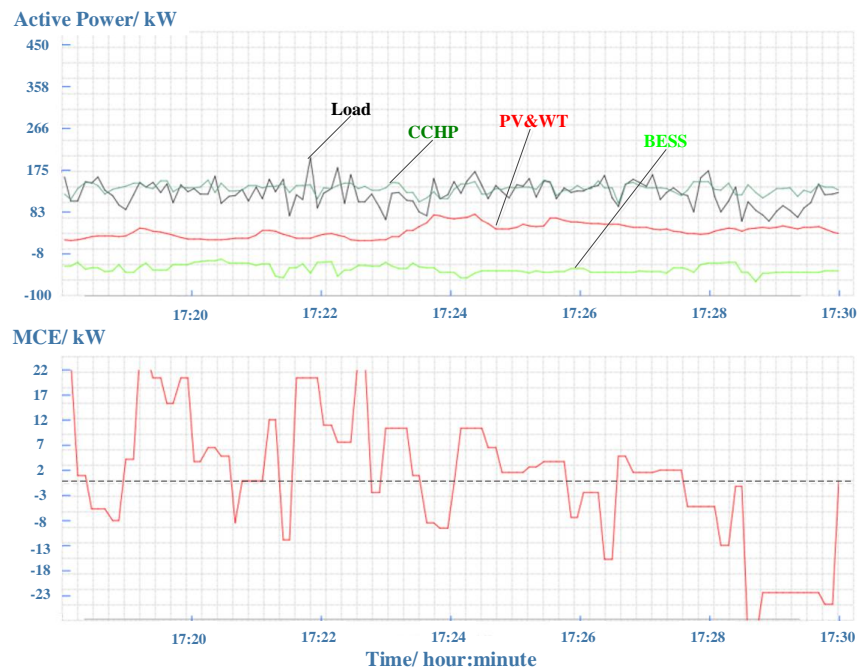

Fig. 3. The performance of MCE control.

In Fig. 3, the MCE was fluctuating near the zero line, which indicated that the power output of CCHP was maintained within a certain range (± 20 kW) around the target power. And the response speed of MCE control was less than 30 seconds. The BESS was under charge mode because of the light load. During the interval of target power updating, the BESS helped to reduce the unexpected power fluctuations from both load and intermittent distributed sources (PV and WT). Overall, compared to the load variation, the output curve of CCHP was smoothed through the coordination of other PQ sources. With coordinated control, the secure and stable operation of islanded microgrid was improved, and the curtailment of PV and WT was also avoided.

SUMMARY

This paper offers feasible solutions according to some practical problems faced in the implementation of a microgrid demonstration project located in Guiyang, China. A coordinated control architecture composed of primary control and secondary control is provided for the seamless transition of the microgrid and the power sharing among distributed sources during islanded operation. The control method is verified in the field trial test of this practical demonstration application. With MCE control, the power output of V/f source (CCHP) is smoothed in spite of power fluctuations from load and intermittent distributed sources (PV and WT). The control method proposed in this paper fully utilizes the power capacity of PQ sources in islanded operation, and it is of exemplary significance in the exploitation and integration of the distributed sources without droop characteristics in some practical engineering projects.

REFERENCES

- [1] S. Chowdhury et al., 2009, *Microgrids and active distribution networks*, The Institution of Engineering and Technology, 3-8.
- [2] I. J. Balaguer et al., 2011, "Control for grid-connected and intentional islanding operations of distributed power generation", *IEEE transactions on industrial electronics*, vol. 58, 147-157.
- [3] K.H. Lee et al., 2016, "Demonstration project of distribution level microgrid in Penetanguishene of Canada", *CIRED Workshop 2016*, IET, 1-3.
- [4] E. Alegria et al., 2014, "CERTS microgrid demonstration with large-scale energy storage and renewable generation", *IEEE transactions on smart grid*, vol. 5, 937-943.
- [5] D. N. Gaonkar et al., 2009, "Seamless transfer of microturbine generation system operation between grid-connected and islanding modes", *Electric Power Components and Systems*, vol. 37, 174-188.
- [6] S. H. Lee et al., 2013, "Power management and control for grid-connected DGs with intentional islanding operation of inverter", *IEEE transactions on power system*, vol. 28, 1235-1244.
- [7] W. Gu et al., 2017, "An online optimal dispatch schedule for CCHP microgrids based on model predictive control", *IEEE transactions on smart grid*, vol. 8, 2332-2342.
- [8] J. Wang et al., 2017, "Optimal joint-dispatch of energy and reserve for CCHP-based microgrids", *IET Generation, Transmission & Distribution*, vol. 11, 785-794.